

CONSULTANTS

# ONE PIECE TANK MANUAL

Manufacturing Tanks Since 1973



**TRICEL**  
GENERATIONS OF INNOVATION



For more information contact us today at:  
[watersales@tricel.ie](mailto:watersales@tricel.ie) or [www.tricelwater.ie](http://www.tricelwater.ie)

ASSOCIATION OF  
TANK AND CISTERN  
MANUFACTURERS  
SETTING THE STANDARDS



APPROVED MEMBER



# TABLE OF CONTENTS.



**TRICEL**  
GENERATIONS OF INNOVATION

1. Guidelines for locating water tanks .....	3
1.1 General .....	3
1.1.1. Water tanks on top of buildings .....	3
1.1.2 Water tanks on elevated structures .....	3
1.1.3 Potable water tanks .....	3
1.1.4 Foundation Requirements .....	4
1.1.5 Offloading .....	4
2. One piece tanks .....	5
2.1 Construction .....	6
2.2 Bracing .....	6
3. Condensation trays .....	7
4. Tanks insulated and finished to Format 30 .....	7
5. Pipe connections for cold water storage tanks .....	8
6. Pipe connections for insulated cold water storage tanks .....	8
7. Format 30 fittings .....	9
a. Screened air inlet vent .....	9
b. Screened overflow .....	9
8. Maintenance recommendations for one piece water storage tanks .....	10
9. Glossary of terms.....	11

# 1. Guidelines for locating water tanks

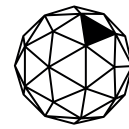

**TRICEL**  
GENERATIONS OF INNOVATION

## 1.1 General

The following recommendations are generally for elevated tanks, as tanks at elevated positions can cause serious damage to the surrounding area in the event of wall, pipe or structural support failure resulting in water spilling out at a fast rate. Consideration must be given to minimize the effects of such an occurrence, in terms of the positioning of the tank and regular inspection.

- Water tanks should be located to prevent water damage or consequential loss in the event of leakage howsoever occurring.
- All tanks which are located above water sensitive areas should have a bund wall around them with adequate evacuation ducts.
- All other tanks should have condensation or drip trays to prevent nuisance damage and to keep floors dry.
- Any overflow should be discharged externally from the building, or if not possible due to tank location i.e., in basement, to a receptacle capable of accepting the full flow of water to then subsequently discharge safely preventing any damage to the building fabric in the event of a ball valve malfunction.

Problems may arise with tanks due to, lack of maintenance, failure of the structural supports underneath the tanks, contaminated water attacking the internal fittings, ball valve failure where overflows were not fitted, vandalism etc.

### 1.1.1 Water tanks on top of buildings

Water tanks located on top of any building should be sited at least 1.2 meters away from the edge of the building.

It would be preferable if the water tank was sited 1.5 times the height of the tank away from the edge of the building. In the event of failure, this would allow the water to spread itself over a much wider area before spilling over the edge of the building and possibly taking personnel or debris with it. Tanks in exposed places may be susceptible to movement in high winds, especially when empty.

### 1.1.2 Water tanks on elevated structures

For water tanks located on top of elevated structures, a walkway of at least 1 meter should be provided all around the water tank to allow for maintenance and inspection. This walkway should comply with health and safety regulations.

### 1.1.3 Potable water tanks

To comply with the Health & Safety Executive regulations on the Control of Legionellosis, Cold Water Storage Tanks must be in areas that are "readily accessible for cleaning". Regular Maintenance and Inspections as required by Health & Safety Legislation.

- All tanks shall have a cover suitably supported.
- Float operated valves and other controls should be readily accessible.
- There should be sufficient clearance to allow for inspection, cleaning of internal surfaces and maintenance.

#### **1.1.4 Foundation Requirements**

All tank foundations should be designed and constructed in accordance with all current regulations, guidance and standards where necessary. The cold water storage tank should be supported on a flat, level, rigid platform which is capable of safely withstanding the weight of the tank when filled with water to the rim and fully supporting the bottom of the tank over the whole of its area. The platform should extend a minimum of 150mm in all directions beyond the edge of the maximum dimensions of the tank.

#### **BS EN 13280**

The top surface of the foundation, whether it is flat screed concrete, steelwork, support walls or pillars, should be flat, level, and free from any local irregularities. It should not vary more than 2mm in any 1m, or a total of 6mm in any 6m, measured laterally or diagonally. If foundations are to be provided by suspended floors or beams, then the foundation should be constructed so that when the tank is full, the combined deflections should not exceed 1/500th of the span.

#### **1.1.5 Offloading**

- Tanks should be offloaded and moved using either a tail lift or a forklift. If any other method of lifting is going to be used, please contact Tricel customer services team for assistance.
- Do not attempt to move a tank containing any water.
- Do not use chains to lift the water storage tank.
- Tanks should always be placed on a flat and level surface; care should be taken to ensure that there are no sharp protruding objects present that might damage the base.

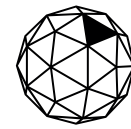

## 2. One Piece Tanks

Tricel manufactures a variety of one piece cold water storage tanks. They are durable, one piece constructions, that are easy to install and represent excellent value for money. These come in sizes from 45 to 6000 Litres. One piece tanks can also be supplied insulated to Format 30, thus meeting Dublin Corporation requirements for break tanks.

The following sizes are available ex-stock.

### 2.1 Table of Tank Sizes.

			INSULATED		
Part No	Designation	Litres	Length (mm)	Width (mm)	Height (mm)
220798	TW45	45	495	370	345
220800	TW180	180	700	575	575
220802	TW225	225	1200	535	480
220803	TW315	315	1240	585	585
100782	TW500	500	1130	755	840
100277	TW700	700	1645	1035	590
100804	TW1000	1000	1180	1180	1040
100765	TW1500	1500	1685	1185	1040
100762	TW2000	2000	2185	1185	1040
100799	TW2250	2250	1680	1180	1560
100798	TW3000	3000	2180	1180	1560
100755	TW3600	3600	2680	1830	1010
100753	TW4500	4500	2680	1830	1260
100752	TW6000	6000	2200	22000	1560

- All of the above capacities are nominal.
- Insulated one piece tanks are complete with insulated covers.
- GRP covers and condensation trays are available for all sizes. Condensation trays are designed where their measurements are no greater than the length and width of the tank.
- When tanks are installed, space is required above for access.

It is important that the base of these tanks be fully supported in use.

- Tricel manufactures condensation trays to suit all sizes of water storage tanks.
- Ensure that the base of the cistern is adequately uniformly supported over its whole area.
- Support and align the pipe so as not to distort the tank, and do not overtighten the back nuts.
- Ensure that the circular holes for fixing pipes have a clean edge, free from notches, and cut them with a hole saw or drill them with a sharp cutter.
- Position the tank so that it is not near any source of heat.
- The tank should not be left unattended during commissioning.
- Check that the internal stays are in place.
- Adequate overflows should be fitted to prevent the tank from being pressurized.
- Tanks in exposed places may be susceptible to movement in high winds especially when empty.

## 2.1 Construction

GRP tank products are manufactured from non-corrosive materials to the requirements of BS EN 13280 and BS EN13121, incorporating the quality control requirements of ISO 9001 Quality Management System, with specific quality control arrangements being based upon BS4549-1 (reinforced plastic moldings), and are independently tested to meet the requirements of Regulation 4 (1) (a) of the 1999 UK Water Supply (Water Fittings) Regulations.

- Internal surfaces in contact with the fluid are smooth isophthalic gel-coated with a high gloss finish to improve resistance to bacteriological growth.
- Resin is high grade orthophthalic, pigmented, and shall be resistant to ultra-violet attack.
- The reinforced glass is to be 'E' glass type and to be long-stranded (40mm minimum).
- The proportion of glass shall be no less than 30% w/w. The external finish shall be totally sealed, be sufficiently robust to withstand normal site handling and transportation.
- External Colour shall be Grey BS 00-A-05.
- All tanks are factory water tested at the manufacturing stage.

This tank must ONLY be used for the storage of water, unless specifically stated on your confirmed order, and where necessary, specialist resins have been used.

All our tanks are suitable for the storage of water up to 30°C. If high temperature resin has been specified for your tank, then storage of water up to 80°C is possible.

## 2.2 Bracing

Internal ties and fasteners, if fitted, are constructed in high grade stainless steel 316 Grade A4, compliant with EN 1.4401 / EN 1.4436, SAE 316 and UNS S31600.

External reinforcement/fasteners, if incorporated, are mild steel construction to BS 3692 and galvanized to BS EN ISO 1461

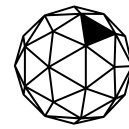

**TRICEL**  
GENERATIONS OF INNOVATION

### 3. Condensation trays

- Tricel manufactures condensation trays to suit our range of one- piece water tanks. We can also manufacture bespoke condensation trays (longer lead time on these items).
- Condensation trays should be used in any instance where condensation, drips from pipe work or from tanks could cause nuisance damage or render floors wet and slippery.
- Condensation trays should be water tested at time of testing the tank.

A condensation tray is not a substitute for a bund wall or for tanking out a room.

**Appropriate overflows must be fitted as close as possible to the base of the tray, these must be fitted before the tank is filled.**

### 4. Tanks insulated and finished to Format 30

- Current legislation state that water hot or cold. In any premises that might be used for human consumption must be of potable quality.
- In addition to tank material specifications, there are now further requirements for lid design, the screening of vents, breathers, overflows, warning tell-tale pipes and the provision of insulation which will help prevent freezing and also help keep water as cool as practicable, ideally less than 20°C.
- Format 30 is Tricel's description of tanks with covers, complete with screened vents, overflows, warning pipes etc. and having side wall and lid with a (u) value of 2.5/m<sup>2</sup>K. This value meets the requirements of section 30 of the water bye laws in the majority of situations. Tanks in boiler rooms etc. may also need additional base insulation. The purchaser can specify extra requirements or thermal transmittance after considering the period of protection necessary, the tank location and the surrounding conditions.

Please note that insulation slows down but does not prevent heat loss or gain protracted periods  
Additional information is available in BS EN 806 & BS 8558.

## 5. Pipe connections for cold water storage tanks



**TRICEL**  
GENERATIONS OF INNOVATION

- If the tank is to be drained down at a fast rate or by pumps etc., Tricel should be informed so that adequate vents can be placed on the tank. The standard vent is 3/4"
- Connections of 100mm (4") nominal bore or over require studed flange pads to suit BS 10:2009, table D&E flanges for pipework connections.
- Connections below 100mm (4") nominal bore may be made by cutting holes in situ. First determine whether single or double sided connections are required and cut a hole in panel to suit external pipe diameter.
- For connections over 50mm (2") nominal bore use two flanges screwed BS21 taper thread, drilled to BS10. Offer one flange to panel concentric with hole and transfer drill bolt holes into panel. Set one flange to external pipe and using appropriate gaskets, assemble external flanged pipe using other flange as an internal backing plate. Finally bolt up.
- For double sided connections proceed as above, replacing internal flange with the required fitting, e.g. ball valve, strainer basket etc.
- For connections of 50mm (2") nominal bore or less proceed as above or alternatively use threaded flanges or back nuts (with rubber gaskets) on standard long screw to BS1387.

All pipework must be self-supporting. If welded or brazed-on flanges are used, all heat must be dissipated before connections are made to the tank. Holes may be cut with normal metal working tools.

## 6. Pipe connections for insulated cold water storage tanks

The areas where pipe connections can be made on insulated tanks are more restricted than in standard tanks, there is a recess in the insulation to allow for the pipe connection.

Standard insulated tanks come with insulation recesses. More can be supplied if required.

Recesses for connections can be made in different locations but Tricel must be notified of this prior to order.

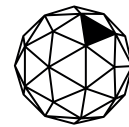

## 7. Format 30 fittings

### a. Screened air inlet vent.

One of these is to be fitted to the lid in every Format 30 Tank, the hole for the vent will be pre- drilled in the lid panel. Larger tanks may require more than one vent.

**Note:** During commissioning the air inlet vent should be checked to ensure that it is fitted correctly to the tank.

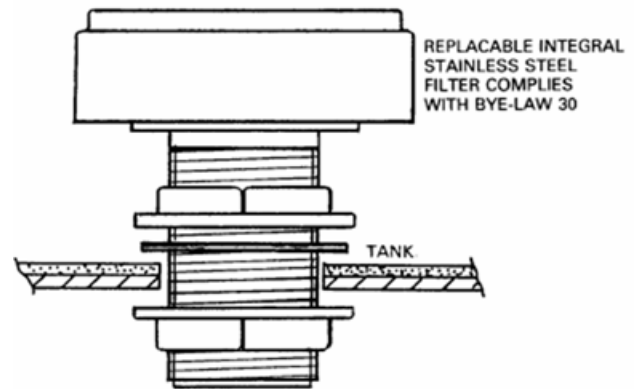

### b. Screened overflow

A 1 1/2" screened overflow is supplied with each Format 30 tank. Please contact us if a different size is required. These are not fitted by Tricel.

Overflows larger than 1 1/2" have a different configuration.

Warning or tell-tale pipes if specified must also be screened. Overflow and Vent connections shall be supplied with Screens with 0.65mm mesh in line with requirements of BS 13280 to protect against the ingress of insects and particles & should be fitted to maintain required air gaps.

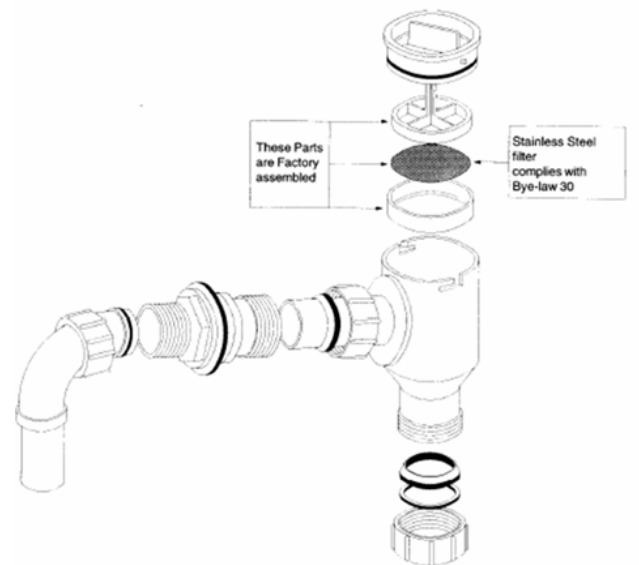

### Byelaw 30 fittings

The overflows should be twice the cross-section area of the inlet.

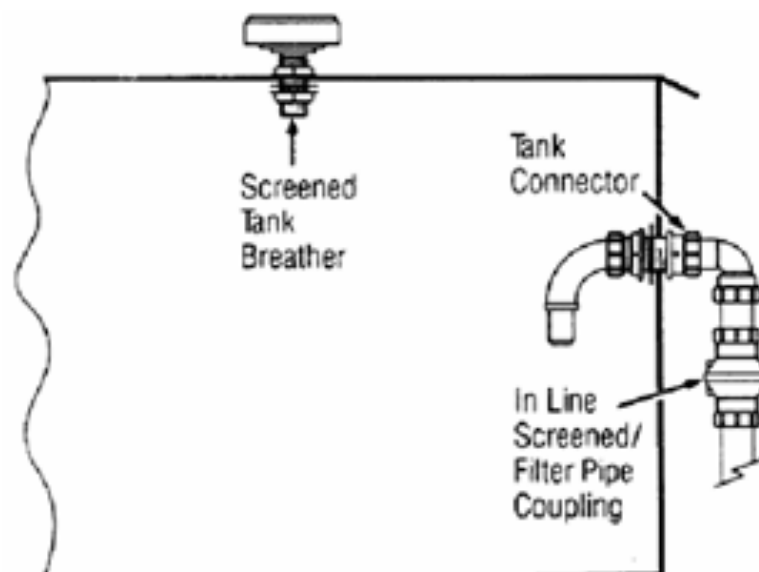

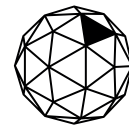

## 8. Maintenance recommendations for one piece water storage tanks

Maintenance interval: Minimum of once yearly.

The main cover forms part of the structure and should not be removed unless the tank is empty. As GRP tank products are manufactured from non-corrosive materials, they require little or no specific maintenance other than good housekeeping.

### Checklist, Operation and maintenance (O&M)

- All internal supports should be checked for corrosion, if corrosion is found it should be rectified immediately.
- Check generally for leaks and drips. Inspect the tank externally for any signs of dampness around its base which may be the result of leaking tank connections, condensation, damage, or overflowing. Rectify as necessary.
- Check that all pipework connected to the tank is suitably braced.
- Inspect the effectiveness and operation of the incoming float-valve and/or isolation valve arrangement.
- Inspect the cleanliness of the tank and washout, if necessary, by means of opening the drain valve. Additional washing down with a hose may be necessary.
- Check that the structural supports under the tank is in good condition.
- Inspect the tank fittings to ensure that any air vent, overflows, warning pipes and filter screens are clean and unobstructed, manways and inspection hatches are secure and sealed, and any access ladders are securely fixed
- If insulated, check that insulation and the manhole is securely fixed and not damaged, if they are damaged then the tank is not in compliance with Byelaw 30.
- If not insulated in accordance with Byelaw 30, ensure the persons cannot consume the water from the tank. We can advise on upgrading the tank to Byelaw 30 standard.
- If there is a condensation tray with the tank, ensure that it has an overflow fitted and that it had not been damaged.
- If the tank has a cover and is sited out of doors, check that the cover has not suffered structural damage and that it is securely bolted down.
- If the area underneath/adjacent to the tank has become water sensitive check that the tank room is bunded with adequate escape ducts.
- If the tank room is bunded, check that it is in good condition.
- For most installations a test of water quality should be carried out by a competent environmental hygiene technician every 12 months. If test results are unacceptable, the tank should be chlorinated to improve water quality. (Note: Where water quality is unacceptable consideration needs to be given to upstream or downstream sources of contamination).
- Any cleaning of the tank and associated water system, should be carried out in accordance with the Health & Safety Executive Guidelines on the Control of Legionellosis 2009.
- Bird droppings can be acidic and could damage the outer gel coat, and this should be removed as soon as possible to prevent any possible damage.
- The inspection period for the above should be based upon a risk assessment by the customer for

any possible damage, dependent upon the environment the system is located in.

- Our tanks have a corrosion free design so once installed there is virtually no requirement to attend to its structure. We do, however, recommend inspecting the tank annually in accordance with BS EN 806-5.
- Ultimately, it is the owner's responsibility that the tank continues to comply to any relevant standards dependent upon the systems specific use, and the maintenance requirements therein to comply.
- The tank is not considered to be recyclable and should therefore be disposed of in accordance with local environmental/authority guidelines at that time.

**Note:** Further information on the health and safety aspect, reference water quality is available in BS6700.

### **Warranty claims**

In the event of any issue arising within the warranty period of the supplied product, please contact customer services team for assistance.

### **Repairs and replacement parts**

In the event of any accidental or 3rd party damage to the tank or components, please contact customer service team to arrange an assessment of the damage and advise on available options of part replacement or repairs.

**Note:** We recommend the installation of two tanks in buildings as this will facilitate maintenance of tanks without effecting the water supply to the building.

### **Leakage test:**

The duration of the test should be a minimum of 24 hours, commencing at least 2 hours after the tank has been filled. The tank should be inspected at regular intervals and not deserted during commissioning (first filling with water). The leakage test is not carried out by Tricel.

## 9. Glossary of terms



**TRICEL**  
GENERATIONS OF INNOVATION

**One piece tank:** Rectangular fixed containers assembled for the storage of water at atmospheric pressure and at a maximum temperature of 30°C.

**Note:** This temperature is higher than is acceptable for drinking water, which should not normally exceed 20°C.

**Nominal capacity:** Volume contained in a tank, measured up to the top edge of the side walls. Actual capacity: volume contained in the tank up to the maximum working level, this can be between 10 and 50% less than the nominal capacity depending on the size of the tank.

**Bund wall:** Structure situated underneath water tanks. Its purpose is to protect the building from water damage. All water tanks located above areas that are water sensitive should be banded.

**Vent:** Opening to the atmosphere to allow for the movement of air resulting from changes in the water level so that the water always remains at atmospheric pressure.

**Warning pipe:** Pipe so fixed that its outlet, whether inside or outside a building, is in a conspicuous position where the discharge of water can be readily seen.

**Overflow pipe:** Pipe connected to the tank to discharge any overflow therefrom. BS EN 13280:2001. Specification for glass fibre reinforced cisterns of one-piece and sectional construction, for the storage, above ground, of cold water.

**Note:** Tricel believe that the information contained in this brochure is accurate, and is printed for information only. No warrants, express or implied, are contained therein, nor does any legal liability attach to Tricel for any reason whatsoever. Property rights of the subject belong to Tricel, and transfer of these rights is not granted by possession of this document. - April 2024

1057348/6



Please note: Insulation slows down, but does not prevent heat loss or heat gain, over protracted periods. Additional information is available in BS 7491 & BS 6700.

Tricel (Killarney) Unlimited Company, Ballyspillane Industrial Estate, Killarney, Co. Kerry, Ireland.

Tel: +353 (0) 64 6632421 | Email: [watersales@tricel.ie](mailto:watersales@tricel.ie) | [www.tricelwater.ie](http://www.tricelwater.ie)

In accordance with Tricel's normal policy of product development these specifications are subject to change without notice.